

RoHS2.0
Compliant

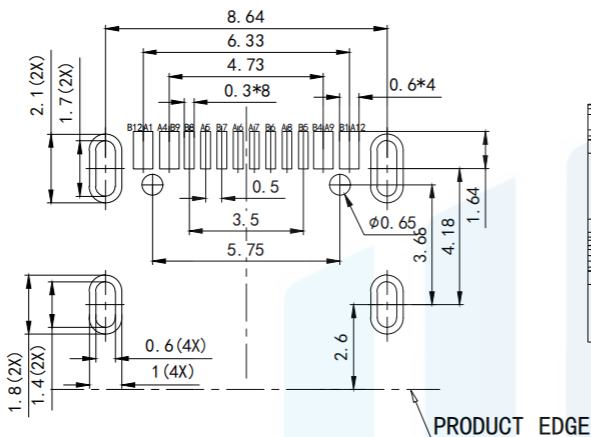

RECOMMENDED P. C. B LAYOUT
TOLERANCE UNSPECIFIED $\pm 0.05\text{mm}$

A1	GND	B12	GND
A4	VBUS	B9	VBUS
A5	CC1	B8	SBU2
A6	D+	B7	D+
A7	D-	B6	D-
A8	SBU1	B5	CC2
A9	VBUS	B4	VBUS
A12	GND	B1	GND
PIN	SIGNAL NAME	PIN	SIGNAL NAME

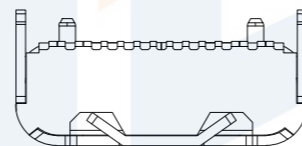
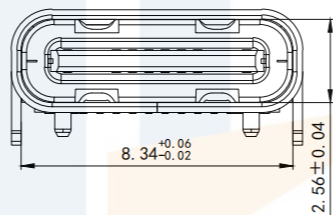
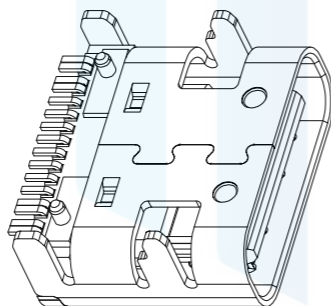

TOLERANCE	
X. XXX	± 0.05
X. XX	± 0.15
X. X	± 0.20
X.	± 0.30
ANGLE	$\pm 5.0^\circ$

PROTECTON

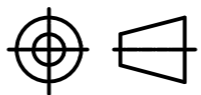

东莞市恒祺电子科技有限公司
Dongguan Hengqi Electronic Technology Co., Ltd

<https://www.hq-dz.com>

phone: 15812872448

TITLE:
TYPE C 16P板上端子SMT外壳带弹
4定位脚插板L=7.35

PART NO: 成品图

DRAWING NO: 7.35*8.34*3.16

DRAWN:

DATE: 18-10-08

UNIT:
mm

CHECKED:

DATE: 18-10-08

SCALE:
FULL

APPROVED:

DATE: 18-10-08

SIZE:
A4

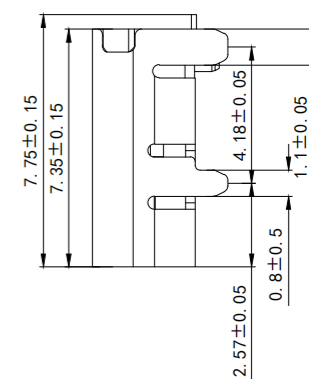
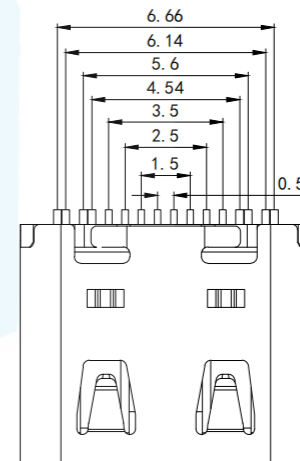
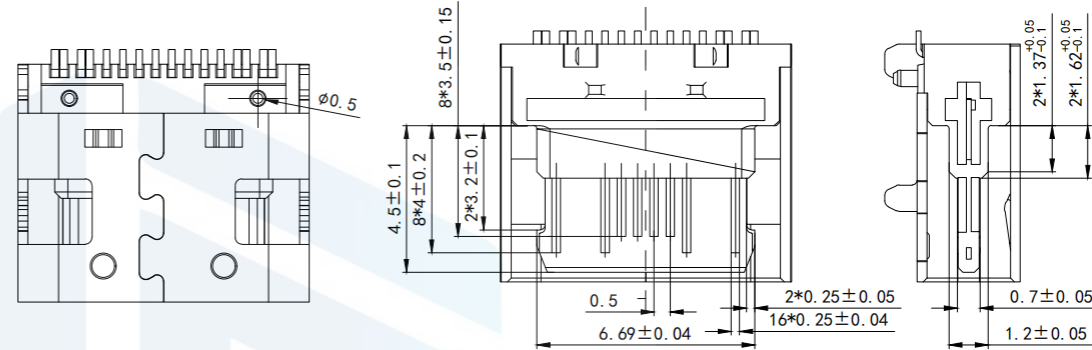

Note:

- Material:
 - Rubber core :LCP+30% G.Ul94V-0
 - Terminal: high conductivity copper C7025/G2680; Bottom 50U "MIN, contact area gold plated (AU 1u") Welding area gold plated G/F
 - Shell :SUS201/SUS304,T=0.30mm; Nickel plating 50U "MIN
 - Middle clip :SUS301;
- Main features:
 - Rated current :3A/5A
 - Contact impedance :40m2 MAX(initial value) 50mS2 MAX(after testing)
 - Insulation impedance :100M2MIN
 - Withstand voltage test :100V AC R. M. S.
 - Overall insertion force :5-20N Overall insertion force :5-20N(after durability) Overall extraction force :8-20N Overall extraction force :6-20N(after durability)
 - Durability :10000 times
 - High temperature resistance :SMT reflow soldering (peak 260° 5°), the plastic should not have bad foaming and melting, discoloration, warping deformation within the tolerance range;
 - The product shall be tested for solder, and the tin sticking area shall reach more than 95%;
 - Salt spray test :24HMIN
 - Operating temperature :-30°C~+85°C